



Heat Transfer Equipment For The Food & Chemical Industries

Web: www.AdvantageEngineering.com

Phone: 317-887-0729

• **Temperature Control Units**

Water & Oil
30° - 500°F

• **Portable Chillers**

Air & Water-Cooled
20° - 80°F

• **Central Chillers**

Air & Water-Cooled
Packages & Modules
20° - 70°F

• **Pump Tank Stations**

Chilled or Tower Water
200 - 3600 gallons

• **Cooling Tower Cells**

45 - 540 tons

• **Filters**

• **Heat Exchangers**

CUSTOM UNITS

If one of our standard models does not meet your application needs, then we can custom build a unit that will! Call us at 317-887-0729 for more details.

Advantage Manufactures A Wide Range of Heat Transfer Equipment Used In Industrial Processing Applications



• **Beverage Production**

- Wineries
- Fermentation Process
- Breweries
- Distilleries

• **Personal Care Products**

- Hair Products
- Lotions
- Make Up

• **Food Production**

- Dough
- Chocolate
- Candies
- Dairy

• **Chemical Processing**

- Drying
- Mixing
- Blending



Heat Exchangers

Evaporative Cooling Towers

Portable Chillers

Temperature Control Units

Central Chillers



Made In America

Heat or Cool Industrial Jacketed Vessels

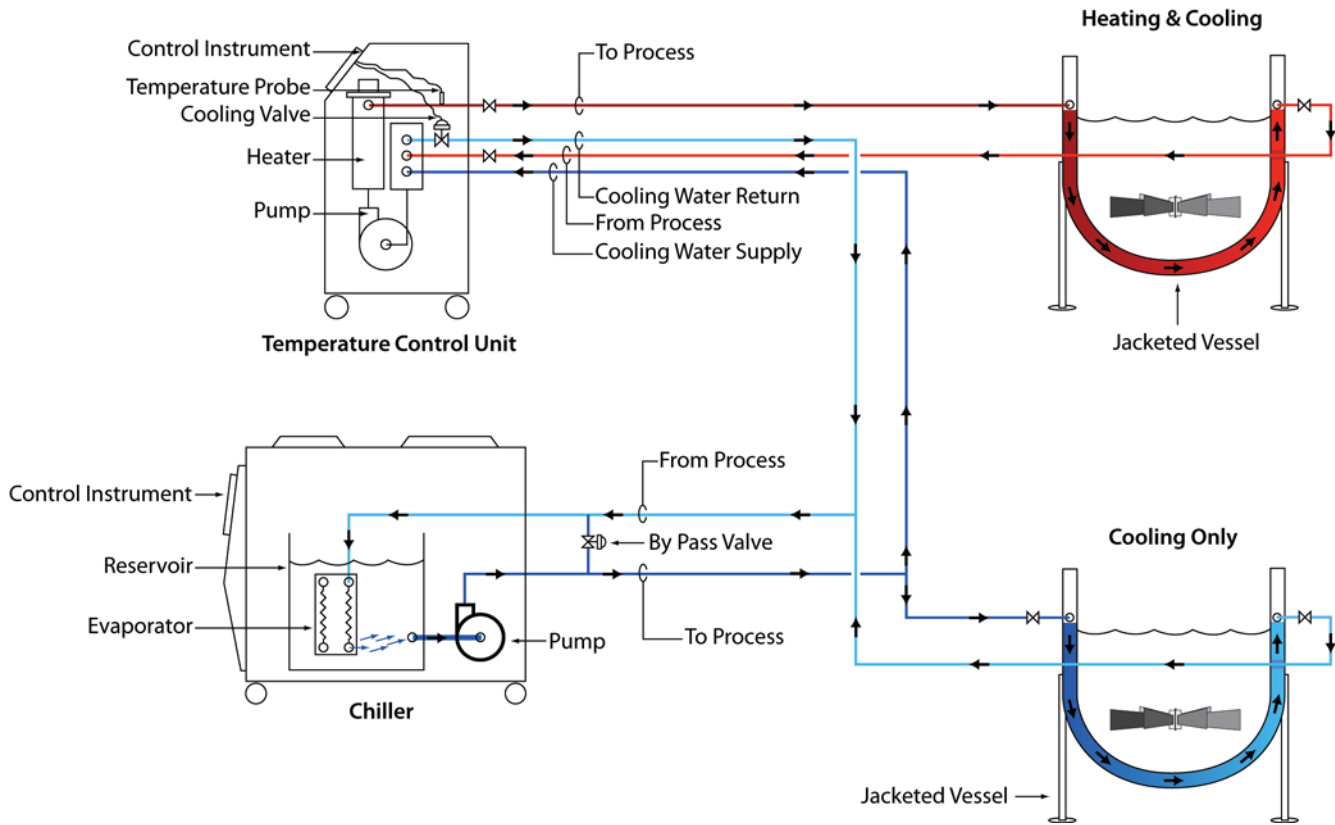

Once Through Cooling or Heating System

Entire Plant Cooling Systems

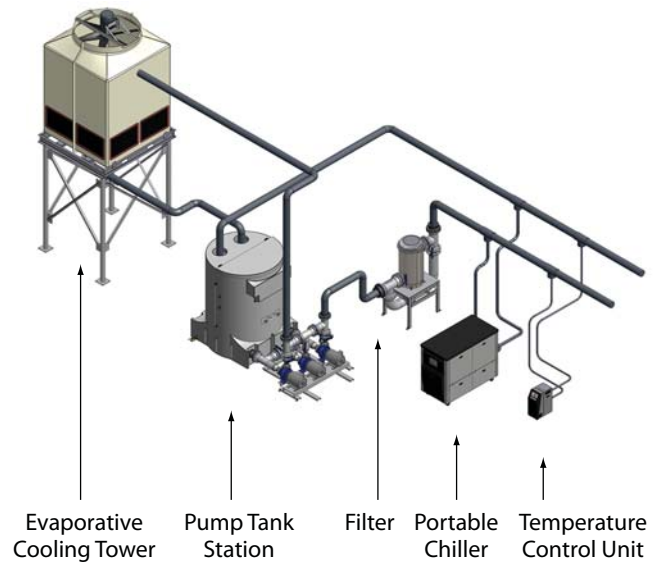
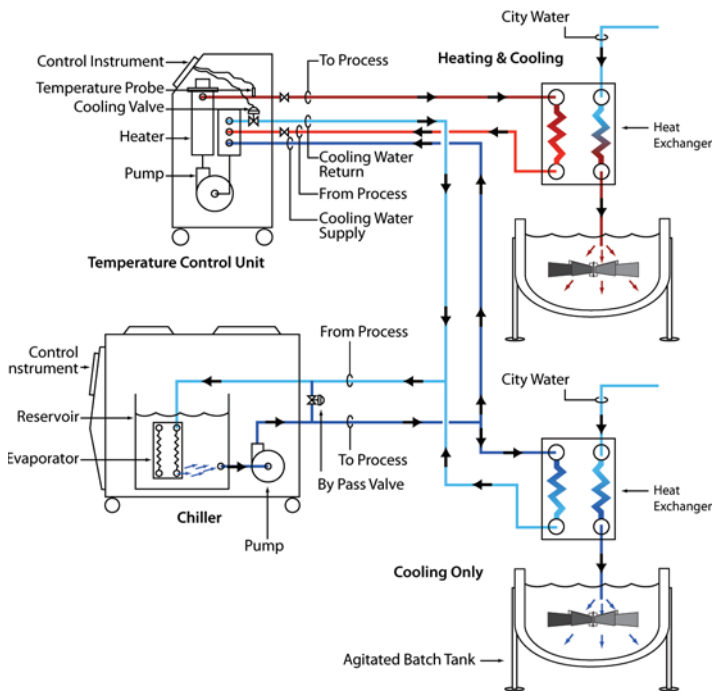

Advantage equipment is not designed for direct contact with food products. Food grade isolation heat exchangers are required.



Phone: 317-887-0729 Web: www.AdvantageEngineering.com

ADVANTAGE PRODUCTS: TEMPERATURE CONTROLLERS · PORTABLE CHILLERS · CENTRAL CHILLERS · PUMP TANK STATIONS · TOWER SYSTEMS · FILTERS

ADVANTAGE ENGINEERING, INC. 525 East Stop 18 Road Greenwood, IN 46142 phone: 317-887-0729 fax: 317-881-1277

web site: www.AdvantageEngineering.com email: sales@AdvantageEngineering.com ©2012 ADVANTAGE ENGINEERING, INC. Form #ADV-908 2/12

SINCE PRODUCT INNOVATION AND IMPROVEMENT IS OUR CONSTANT GOAL, ALL FEATURES AND SPECIFICATIONS ARE SUBJECT TO CHANGE WITHOUT NOTICE OR LIABILITY.